

2 LOCK NUTS
(SEE NOTE 3)

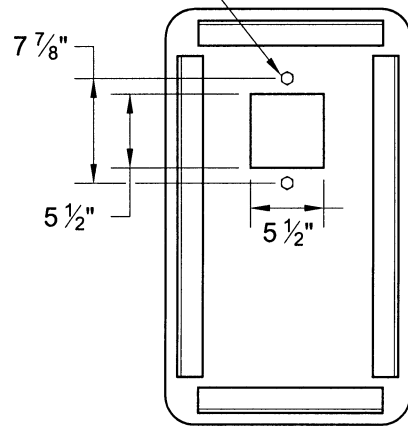

BOTTOM SIDE OF PLATE

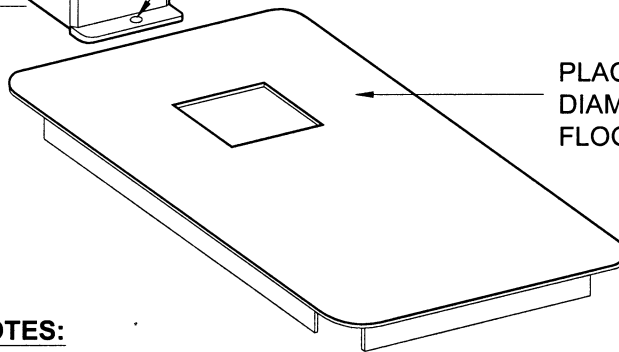

PLACER WATER WORKS
DIAMOND NON-TRAFFIC
FLOOR PLATE CAT #PW/AE36-18M*

PLACER WATER WORKS
CAT # PW/AE36-18M

NOTES:

1. ALL METALS SHALL BE CLEANED WITH DEV PREP 88 BY DEVOE #788T0000*.
2. APPLY 2 TO 3 MILLS THICK OF DEVRAN 224HS CATALYZED POLYAMIDE EPOXY PRIMER* (COLOR: HUNTER GREEN) AND DEVTANE 379 CATALYZED ALIPHATIC URETHANE FINISH* TOP COAT TO THE STEEL CAP AND TUBING WALL.
3. LOCK NUTS SHALL BE WELDED TO THE UNDERSIDE OF THE FLOOR PLATE.

* OR APPROVED EQUAL

(Not To Scale)



**ENGINEERING
DEPARTMENT**

**AIR AND VACUUM RELIEF
VALVE ENCLOSURE**

B. Grewal
BALWINDER S. GREWAL CITY ENGINEER

DATE: JULY 31, 2003
REVISED: NOV. 9, 2004

SHEET NO.
W-11a