

* OR APPROVED EQUAL

** THE USE OF RECYCLED A.B. SHALL NOT BE ALLOWED

CLOW 950*, PAINTED KELLY-MOORE 1700-63 SAFETY YELLOW GLOSS ALKYD RUST INHIBITIVE ENAMEL* (SEE NOTE 3)

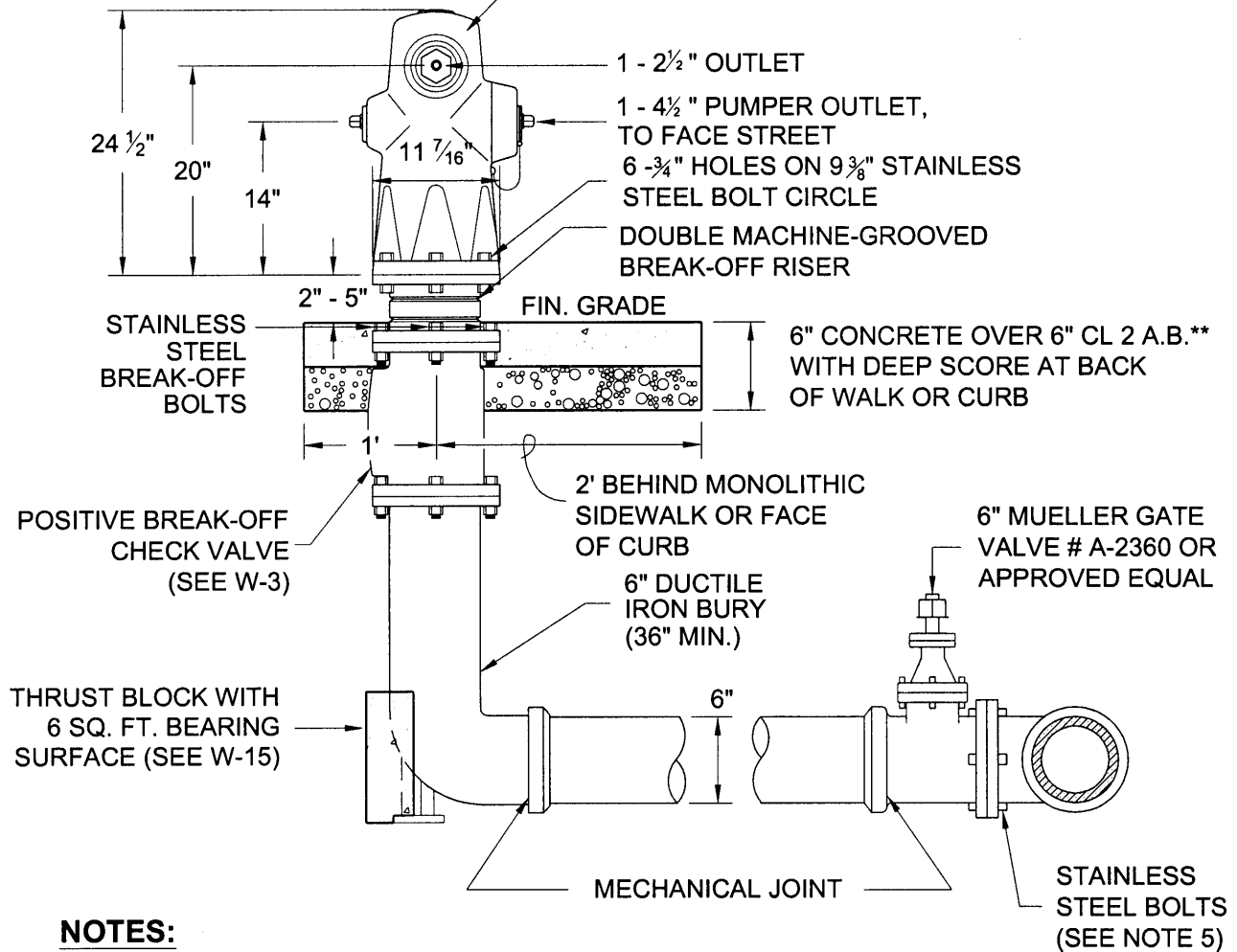

NOTES:

1. FOR RUNS GREATER THAN 35 FEET, A SECOND VALVE SHALL BE PLACED BETWEEN 8 AND 18 FEET FROM THE HYDRANT.
2. PLACE BLUE, TWO-WAY REFLECTIVE PAVEMENT MARKER OPPOSITE HYDRANT 3 FEET IN FROM CENTERLINE OF STREET.
3. HYDRANTS SHALL COMPLY WITH THE LATEST REVISION OF AWWA C503.
4. RED CURB OPPOSITE THE FIRE HYDRANT IS NOT REQUIRED UNLESS DIRECTED BY THE CITY ENGINEER.
5. ALL BOLTS CONNECTING TO THE WATERLINE SHALL BE STAINLESS STEEL.

(Not To Scale)



**ENGINEERING
DEPARTMENT**

**RESIDENTIAL FIRE
HYDRANT INSTALLATION**

B. Grewal
BALWINDER S. GREWAL CITY ENGINEER

DATE: JUN. 20, 2003
REVISED: APR. 29, 2005

SHEET NO.
W-1