

\* THE USE OF RECYCLED A.B. SHALL NOT BE ALLOWED

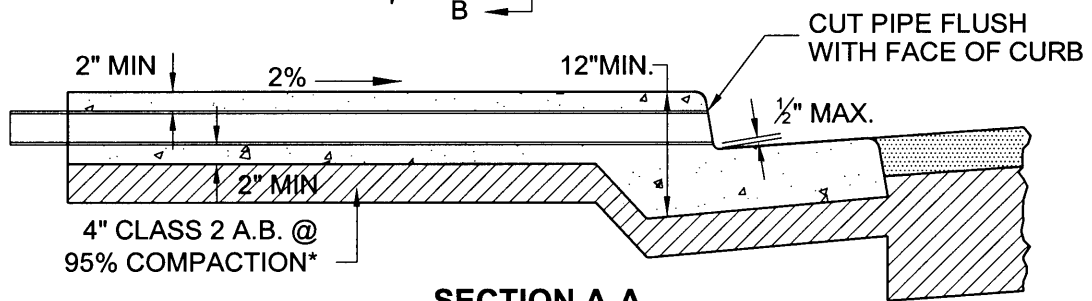

**SECTION A-A**

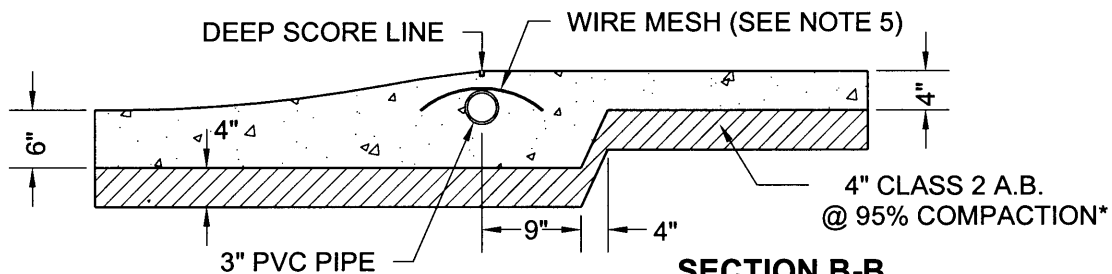

**SECTION B-B**

**NOTES:**

1. TO BE USED ONLY IN SPECIAL CASES AS APPROVED BY THE CITY ENGINEER.
2. CROSS SLOPE OF THE DRAIN SHALL BE 2%.
3. USE A STAINLESS STEEL BAND COUPLING FOR CONNECTION OF YARD DRAIN LINES.
4. SIDEWALK DRAIN SHALL BE CONSTRUCTED AT EACH SIDE OF DRIVEWAY, UNDER DEEP SCORE LINE.
5. WIRE MESH (6-6, 10"x10" WWM) SHALL BE INSTALLED OVER THE PVC PIPE BEFORE CONCRETE POUR.

(Not To Scale)



**ENGINEERING  
DEPARTMENT**

**THROUGH-THE-CURB DRAIN**

BALWINDER S. GREWAL CITY ENGINEER

DATE: OCT. 31, 2000  
REVISED: JUNE 20, 2003

SHEET NO.  
**ST-27**