

CTS TERMINAL BOX

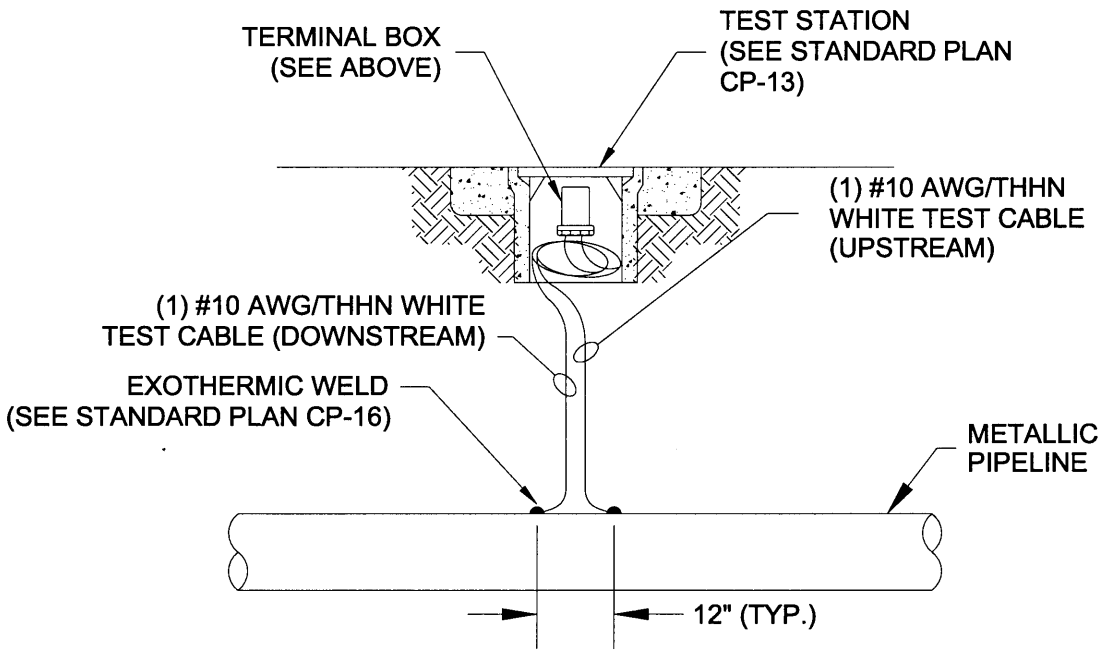

NOTES:

1. IDENTIFY CABLES PER STANDARD PLAN CP-15.
2. LOCATION TO BE SHOWN ON THE PLANS OR AS DIRECTED BY THE CITY ENGINEER.

(Not To Scale)



**ENGINEERING
DEPARTMENT**

CORROSION TEST STATION (CTS)

Balwinder S. Grewal

BALWINDER S. GREWAL CITY ENGINEER

DATE: APR. 15, 1999
REVISED: JUNE 20, 2003

SHEET NO.
CP-1